

Z-BAR WITH RETURNS

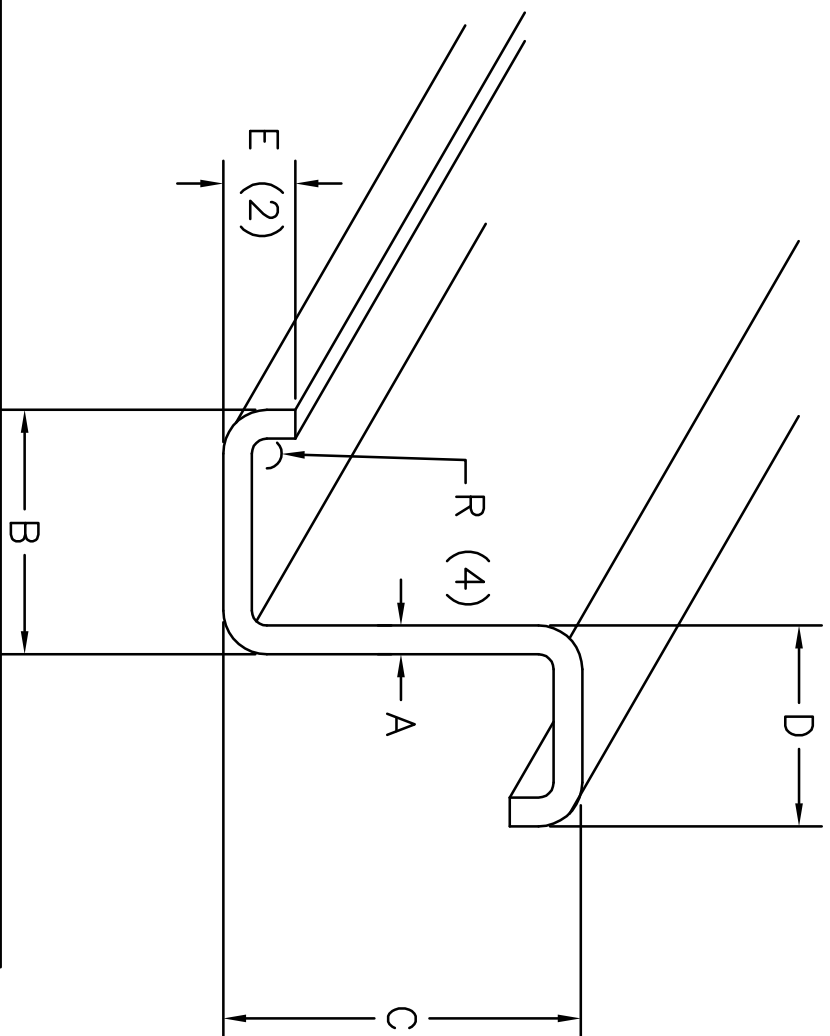

CUSTOM DIMENSIONS

- A—Thickness _____
- B—Flange _____ (O.D. or I.D.)
- C—Web _____ (O.D. or I.D.)
- D—Flange _____ (O.D. or I.D.)
- E—Returns _____ (O.D. or I.D.)
- R—Radius _____ (I.D.)

Material Type _____

Material Finish _____

Length _____

Quantity _____